

Master Pusher

MP50/400



The Master Pusher Range of Electric Powered Tugs - Move Loads of up to 100,000 Kgs

The Master Pusher is the most effective way to push wheeled loads that require no steering. With an application on rails a pushing capacity of up to 100,000kg can be achieved. The direct gearbox and motor supplies endless power, supported by the Tug's tough steel chassis. The adjustable height coupling adds flexibility as standard making it very easy to work with your existing equipment.

Benefits

- Electric tug which operates on rough terrain
- Increases productivity
- Low maintenance, high power electric tug
- Reduces manual handling
- Improves safety
- Reduces compensation claims
- Powerful yet easy to use electric tug
- Compact size
- Supplied with full 1-year guarantee



Master Pusher

MP50/400

Additional equipment



Safety pack including strobe and bleeper



Two speed selector switch



Emergency stop

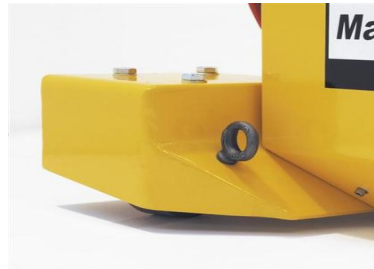

Lifting eyes

Dimensions

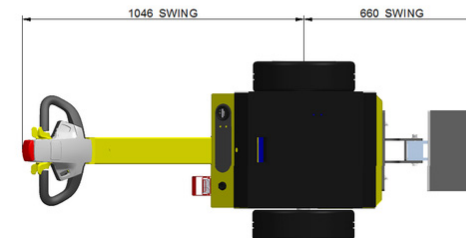
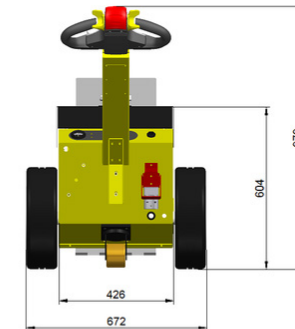
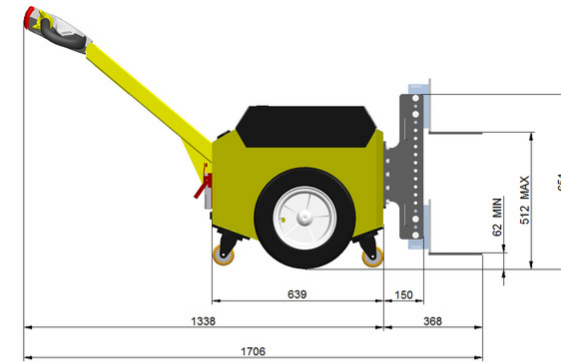

Identification

Product	MP50/400 DC Series
Maximum recommended load weight	40000 kg
Machine weight (excluding battery)	170 kg
Drive type	Electric
Braking	Regenerative
Parking brake	Electromagnetic
Drive wheel type	Industrial Pneumatic
Drive motor power	1.5 kw
Controller type	Series Wound DC
Maximum programmable speed	6 Kph

Battery options

70 amp/hr flooded lead acid vented (standard)	80/54.8kg/0.949 discharge rate%/Wt/km(1)
105amp/hr flooded lead acid vented (upgrade)	80/73.5kg/1.423 discharge rate%/Wt/km(1)
102 amp/hr 24V maintenance free (option)	80/71.3kg/1.38 discharge rate%/Wt/km(1)

Charging options

15 amp wall mounted 110 - 240V input vented (standard)	425/274/280mm/6.4hr L/W/H/charge time(2)
30 amp wall mounted 110 - 240V input vented (upgrade)	425/274/280mm/5hr L/W/H/charge time(2)
15 amp wall mounted 110 - 240V maintenance free (option)	425/274/280mm/6.4hr L/W/H/charge time(2)
12.5A on board 240v vented or maintenance free (option)	7.5hr charge time(2)

Additional equipment

Safety pack including strobe and bleeper
 Foam filled drive wheels
 Two speed selector switch
 Emergency cut out button
 Keypad switch (9 operators)
 Lifting eyes

Male coupling options

Male height adjustable box coupling system
 Male height adjustable L shaped push plate
 Male coupling roller attachment

Female coupling options

Female 10mm box coupling with pin
 Female 15mm box coupling with pin

Packaging

Export packaging sea/road freight 1570/820/1340mm/20.15 L/W/H/kg

(1)based on continuous use with 75% maximum recommended load weight. (2)based on standard battery discharged by maximum value.



MasterMover

Retailquip Pty Ltd
P.O. Box 550,
Samford, Brisbane
Queensland, 4520
Australia
Telephone: 07 3289 6661
Fax: 07 3289 6662
Email: thd@retailquip.com
Web: www.mastermover.com.au

Designed and manufactured in the UK

MasterMover® is a Registered Trade Name. All Rights Reserved. ©2009 MasterMover® Ltd.

We operate a policy of continued improvement in our product range. We therefore reserve the right to amend specifications and descriptions at any time without prior notice.