

Master Tug

MT5/400



The Master Tug Range of Pedestrian Electric Tugs - Move up to 25000 Kgs

The Master Tug is an electric pedestrian tug that can pull, push and steer wheeled loads from 50 to 25000Kg. Traction is the key to moving heavy loads so the Master Tug is designed to get all the traction it needs by using the coupling system to transfer load weight to the drive wheel. It's very effective and very easy to use making it perfect for any business.

Benefits

- Increases productivity
- Electric pedestrian operated tug
- Reduces manual handling
- Improves safety
- Reduces compensation claims
- Powerful yet easy to use electric tug
- Compact size
- Supplied with full 1-year guarantee



Master Tug

MT5/400

Additional equipment



Safety pack including strobe and bleper



Two speed selector switch



Extra grip rubber drive wheel



Lifting eyes



Lockable lid

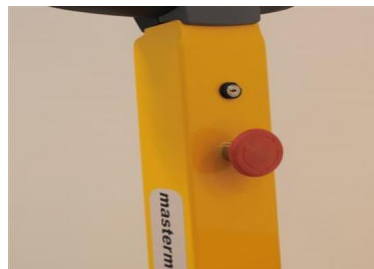

Emergency stop

Dimensions

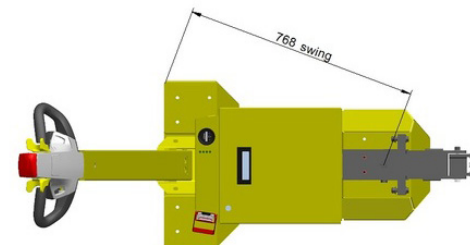
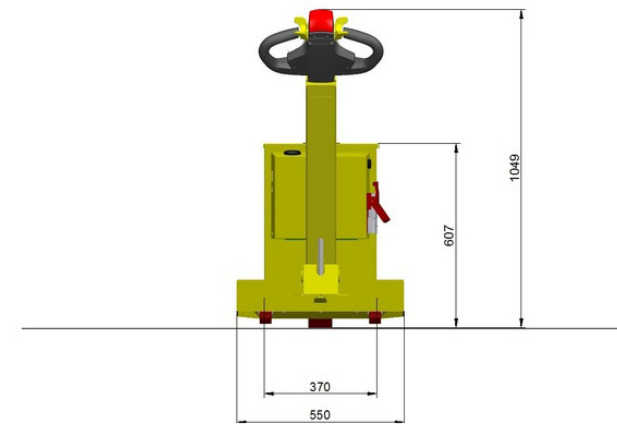
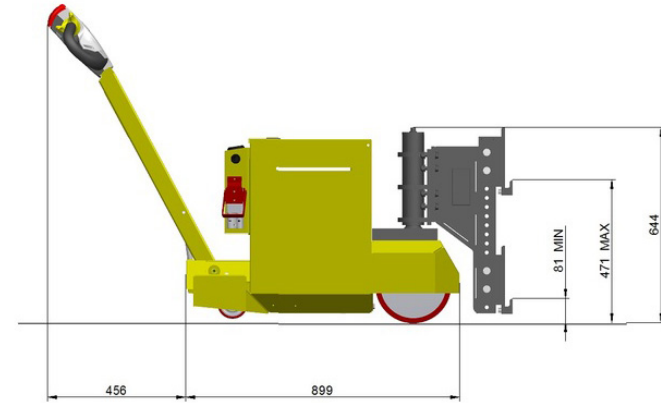

Identification

Product	MT5/400 DC sepex
Maximum recommended load weight	4000 kg
Machine weight (excluding battery)	180 kg
Drive type	Electric
Braking	Regenerative
Parking brake	Electromagnetic
Drive wheel type	Polyurethane
Drive motor power	1.2 Kw
Controller type	Sepex DC
Maximum programmable speed	6 Kph

Mast options

Hydraulic lift and lower (painted finish)	1000 Weight transfer Kg
Manual screw jack mast with safety lock and handle	500 Weight transfer Kg

Battery options

70 amp/hr vented (standard)	80/54.8kg/2.97 discharge rate%/Wt/km(1)
105amp/hr 24V vented (upgrade)	80/73.5kg/4.45 discharge rate%/Wt/km(1)
102 amp/hr 24V maintenance free (option)	80/71.3kg/4.326 discharge rate%/Wt/km(1)

Charging options

15 amp wall mounted 110 - 240V input vented (standard)	425/274/280mm/6.4hr L/W/H/charge time(2)
15 amp wall mounted 110 - 240V input maintenance free (option)	425/274/280mm/8.8hr L/W/H/charge time(2)
12.5A on board 110-240V vented or maintenance free (option)	7.5hr charge time(2)

Additional equipment

Safety pack including strobe and bleeper
 Extra grip rubber drive wheel (wet surface)
 Two speed selector switch
 Emergency cut out button
 Keypad switch (9 operators)
 Lifting eyes

Male coupling options

Male height adjustable combi coupling system
 Male height adjustable box coupling

Female coupling options

Female combi coupling system
 Female 10mm box coupling with pin

Packaging

Export packaging sea/road freight 1200/750/1370mm/13.5 L/W/H/Kg

(1)based on continuous use with 75% maximum recommended load weight. (2)based on standard battery discharged by maximum value.



MasterMover

Retailquip Pty Ltd
P.O. Box 550,
Samford, Brisbane
Queensland, 4520
Australia
Telephone: 07 3289 6661
Fax: 07 3289 6662
Email: thd@retailquip.com
Web: www.mastermover.com.au

Designed and manufactured in the UK

MasterMover® is a Registered Trade Name. All Rights Reserved. ©2009 MasterMover® Ltd.

We operate a policy of continued improvement in our product range. We therefore reserve the right to amend specifications and descriptions at any time without prior notice.