

SM Plus

SM100 Plus



SM Plus - Compact Electric Tug to move up to 1400 Kgs

The new SM Plus range of compact electric tugs is designed for industry. It's ideal for moving wheeled loads of various types on uneven surfaces. If you have a High Tech vessel or a simple trolley to move, the SM Plus pedestrian operated tug will provide the power you need. The flexible attachment connects with force so it can retain the load and with variable speed and auto stop as standard, materials handling has never been so safe and efficient.

Benefits

- Compact size for space restricted environments
- Reduces risk to employees
- Tug Turns at 90 degrees
- Effective connection method
- Works on uneven surfaces and slopes
- Very, very easy to use Compact Tug
- Stops and controls the load



SM Plus

SM100 Plus

Additional equipment



Available in stainless steel



LED front lamp 24V



Keypad switch (9 operators)



Interchangeable powerpack

Dimensions

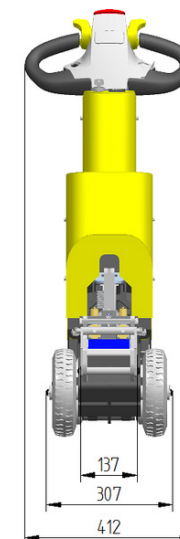
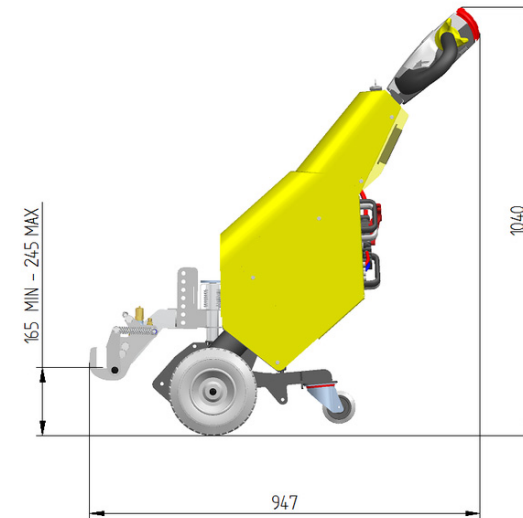

Identification

Product	SM100 Plus Hydraulic
Maximum recommended load weight	1400 kg
Machine weight (excluding battery)	97 kg
Drive type	Electric
Braking	Regenerative
Parking brake	Electromagnetic
Drive wheel type	Rubber Non marking
Drive motor power	2 x 0.22 kW
Controller type	110 DC Permanent

Batteries

27amp/hr maintenance free (standard)	80/16.3kg/2.88 discharge rate%/Wt/km(1)
18amp/hr maintenance free interchangeable (option)	80/19kg/1.924 discharge rate%/Wt/km(1)

Charging

6amp/hr charger 110 - 240V maintenance free (standard)	180/140/100mm/4.5hr L/W/H/charge time(2)
3amp/hr on board charger 110 - 240V input maintenance free (option)	180/140/100mm/8hr L/W/H/charge time(2)

Additional equipment

LED front lamp 24V
SM keypad switch (9 operators)

Male couplings

SM Hyd U channel coupling 50hx25d (mm)
SM Hyd catchbox coupling 50hx25d (mm)
SM cable catchbox coupling 50hx25d (mm)

Female couplings

A-Frame straight female adapter assembly
A-Frame angled female adapter assembly

Packaging

Export packaging sea/road freight 1110/500/1200mm/9.2 L/W/H/kg

(1)based on continuous use with 75% maximum recommended load weight. (2)based on standard battery discharged by maximum value.



MasterMover

Retailquip Pty Ltd
P.O. Box 550,
Samford, Brisbane
Queensland, 4520
Australia
Telephone: 07 3289 6661
Fax: 07 3289 6662
Email: thd@retailquip.com
Web: www.mastermover.com.au

Designed and manufactured in the UK

MasterMover® is a Registered Trade Name. All Rights Reserved. ©2009 MasterMover® Ltd.

We operate a policy of continued improvement in our product range. We therefore reserve the right to amend specifications and descriptions at any time without prior notice.